

# PHM-\*\*-\*\*-1 PULSE HEATING MACHINE 脈衝焊接機



## CHARACTERISTICS :

- \* Unique pulse heat technology provides fastest soldering head heating.
- \* Programmable soldering temperature, heat-up rate and time duration for a wide range of products.
- \* Thermocouple is fixed in close proximity to the working surface & the thermode, thus providing accurate temperature feedback control.
- \* Closed Loop PID temperature control with clearly visible LED display.
- \* Soldering time can be programmable and is triggered by temperature.
- \* Variable compressed airflow allows for ultra-fast head cooling.
- \* Floating Thermode ensures consistent pressure and heat transfer between the thermode head and the parts to be joined.
- \* Programmable pressure switch with LCD display for precise force control.
- \* Standard workpiece holder is mounted on a linear guideway (RSM-LH-\*\*-1) and designed to allow for easy changeover and repeatable operation. To achieve maximum throughput, dual positioning mechanism can be used.
- \* Parts registration is adjusted by micrometer and then secured by vacuum lock.
- \* CCD camera system with magnification lens can be retrofitted for fine-pitch positioning.

## 特點 :

- \* 獨特脈衝式控制, 令焊接頭迅速升溫.
- \* 因應不同產品, 升溫溫度, 速度及時間可供調選.
- \* 感溫器安裝於焊接頭末端並靠近工件, 溫度檢測更精確.
- \* 溫度數控化, 清楚精密.
- \* 到溫啟動計時, 焊接時間可設定.
- \* 可調節之壓縮氣流, 令焊接頭迅速冷卻.
- \* 獨特浮動焊接頭, 確保產品受壓平均.
- \* 備有數字式壓力計, 可預設壓力範圍.
- \* 手動推拉型之夾具乃安裝於滾珠滑道上, 更換簡易, 操作安全. 且雙定位設計, 簡化流程.
- \* 備有真空功能, 調節對位更容易.
- \* 可選加CCD放大系統, 準確地對微間距工件定位.

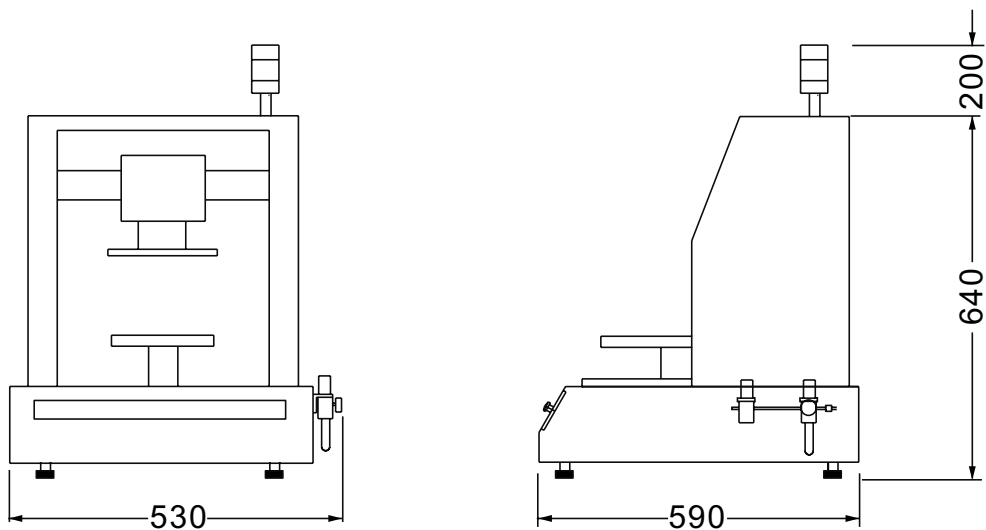

### PHM-LH-\*\*-1

SPECIFICATIONS		規格		
Output Force	出力 N	1) 180	2) 280	3) 410
Temperature Control	控制溫度 °C	0 ~ 400		
Ramp Up Rate	升溫速度	3 speeds		
Accuracy	壓焊恆溫精度 °C	± 6		
Contact Area (Typical)	可壓面積(參考) mm <sup>2</sup>	400		
Compressed Air	壓縮氣壓 Bar	1.0 ~ 6.0		
Pressure Resolution	壓力精度 Bar	0.1		
Movable Vacuum Fixture	真空裝置	1		
Positioning Stage per Workpiece Holder	夾具定位	1 ( Typical ), 2 ( maximum)		
Contact Time	熱壓時間 Sec	1) 0 ~ 5	2) 0 ~ 10	3) 0 ~ 30
Power Supply	電源 Vac	220		
Standard working area (W X D)	標準工作面積(寬X深) mm	150X200		
Max. Working area (W X D)	最大工作面積(寬X深) mm	260X200		



**Smartop Technology Limited**  
創盛科技有限公司

Flat B, 9/F., Wing Yip Ind. Bldg., 21-27 Wing Yip St.,  
Kwai Chung, N.T., Hong Kong.

香港辦事處: Tel : (852) 2790 4433/2790 4438  
Fax : (852) 2790 5918  
Email : smartop@hkstar.com

中國辦事處: Tel : 86-769-556 1321/86-769-556 5921  
Fax : 86-769-556 7183  
Email : adotec@pub.dgnet.gd.cn

